

NEW CANAAN PUBLIC SCHOOLS
INVITATION TO SUBMIT PROPOSALS
NCPS RFP #2015-03

New Canaan Public Schools (NCPS) invites proposals from qualified companies for the Rehabilitation of the Playground and Landscape Project at South Elementary School.

Sealed proposals will be received at the New Canaan Public Schools, 39 Locust Avenue, 3rd Floor, New Canaan, CT 06840 until **April 14, 2015 at 1:00 pm**, at which time they will be opened publicly and read aloud.

The contractor selected for the above project(s) shall be required to enter into a contract with NCPS. Such contract shall require the posting of performance and payment bonds, the submittal of insurance certificates and compliance with Federal, State and Local Laws and ordinances. Bid surety in the form of a bank check, bid bond or certified check in the amount of five percent (5%) of the total proposal price must be submitted with each proposal.

Three (3) copies of the submitted proposal are to be placed in a sealed envelope and addressed to Nancy Harris, Director of Finance & Operations, New Canaan Public Schools, 39 Locust Avenue, 3rd Floor, New Canaan, CT 06840. No proposals will be accepted after the date and time specified. No fax or email submissions will be accepted.

A mandatory walk through meeting for prospective vendors
will convene in the lobby of **South Elementary School,**
8 Farm Road, New Canaan, CT on
April 2, 2015 at 10:00 am
when project details will be discussed and questions answered.

Proposals must be held firm for one hundred twenty (120) days beyond the opening date.

The successful vendor must file a one hundred percent (100%) Performance Bond, a one hundred percent (100%) Labor & Materials Bond and a Certificate of Insurance with the Director of Finance & Operations within ten (10) days of notice of project award.

Plans and specifications are available online at
www.ncps-k12.org

All technical/specification related questions are to be directed to Leigh Jones, RLA,
Eberlin & Eberlin PC, 845-582-0359 or e-mail at eberlinpe@aol.com .

The New Canaan Public Schools reserves the right to accept or reject, without prejudice, any or all proposals or to waive any irregularities therein, or to accept the proposal deemed to be in the best interest of New Canaan Public Schools.

Nancy Harris, Director of Finance and Operations
New Canaan Public Schools

NEW CANAAN PUBLIC SCHOOLS
39 LOCUST AVENUE
NEW CANAAN, CT 06840
203-594-4000

SPECIFICATION COVER SHEET
REQUEST FOR PROPOSAL #2015-03
Rehabilitation of Playground and Landscaping – SOUTH ELEMENTARY SCHOOL

VENDOR MUST ENCLOSE THREE COPIES OF THIS SPECIFICATION COVER SHEET and THREE COPIES OF THE SPECIFICATIONS PRICING SHEETS WHEN RESPONDING TO THIS REQUEST FOR PROPOSAL (RFP)

The NEW CANAAN PUBLIC SCHOOLS reserves the right to reject any and all proposals, or separate parts thereof, requested herein before. When items are mentioned by a particular brand, substitution of equal quality items will be considered only if the proposed substitution is clearly stated. When a vendor fails to so identify a proposed substitution, it will be assumed that he is proposing the exact item requested. The NEW CANAAN PUBLIC SCHOOLS is exempt from the payment of Federal Excise Taxes and Connecticut Sales and Use Tax according to State Statute. Such taxes must not be included in bid prices nor added to any items specified.

INSTRUCTIONS ON RFP DEADLINES AND REQUIREMENTS:

NAME OF RFP: Rehabilitation of Playground and Landscaping – SOUTH ELEMENTARY SCHOOL

TYPE OF RFP: Sealed Proposal QUOTATION #: 2015-03

RFP CLOSURE DATE: Received Until: DATE: April 14, 2015 TIME: 1:00 PM, EST

LOCATION TO FORWARD RFPs:	Nancy J. Harris, Interim Director of Finance and Operations NEW CANAAN PUBLIC SCHOOLS 39 LOCUST AVENUE NEW CANAAN, CT 06840
---------------------------	--

RFP SECURITY: RFP Security Required 5 % RFP Security *Not* Required _____

PREVAILING WAGE: Required X _____ *Not* Required _____

FORMS TO COMPLETE RFP: Submit three copies of all required documentation in a sealed envelope.

Identify Name of RFP on Envelope: Rehabilitation of Playground and Landscaping – South Elementary School RFP # 2015-03

Only fully completed RFP packages will be accepted. The following details describe fully completed RFP packages:

Base Proposal

- Proposal Sheet
- Schedule of Project: Schedule of installation, completion and inspection
- Appendix A – Insurance Procedure Form

NEW CANAAN PUBLIC SCHOOLS
INVITATION TO SUBMIT PROPOSAL

New Canaan Public Schools (NCPS) invites proposals from qualified companies for the Rehabilitation of the Playground and Landscaping at the South Elementary School.

Sealed proposals will be received at the New Canaan Public Schools, 39 Locust Avenue, 3rd Floor, New Canaan, CT 06840 until April 14, 2015 at 1:00 pm, EST, at which time they will be opened publicly and read aloud.

The contractor selected for the above project(s) shall be required to enter into a contract with the NCPS. Such contract shall require the posting of performance and payment bonds, the submittal of insurance certificates and the compliance with Federal, State and Local Laws and ordinances. Proposal surety in the form of a bank check, bid bond or certified check in the amount of five percent (5%) of the total RFP price must be submitted with each proposal.

The Request for Proposal (RFP) is available online at www.ncps-k12.org or by contacting Robert Willoughby, Facilities Manager, at robert.willoughby@ncps-k12.org.

Three (3) copies of the submitted qualifications and proposals are to be placed in a sealed envelope and addressed to Nancy Harris, Interim Director of Finance & Operations, New Canaan Public Schools, 39 Locust Avenue, 3rd Floor, New Canaan, CT 06840. No proposals will be accepted after the date and time specified. No fax or email submissions will be accepted.

The New Canaan Public Schools reserves the right to accept or reject, without prejudice, any or all proposals or to waive any irregularities therein, or to accept the proposal deemed to be in the best interest of New Canaan Public Schools.

Nancy Harris, Interim Director of Finance and Operations
New Canaan Public Schools

PROJECT START DATE SHALL BE JUNE 22, 2015 AND PROJECT SHALL BE COMPLETED BY AUGUST 15, 2015.

I have read and understand the RFP requirement of this RFP specification included for my review herein:

Signature of Company Representative *Date*

TYPED NAME AND

TITLE: _____

COMPANY: _____

ADDRESS: _____

TOWN: _____ **STATE:** _____ **ZIP:** _____

TELEPHONE NUMBER: _____ **FAX:** _____

CELL NUMBER: _____

EMAIL ADDRESS: (Please print clearly or attach business card):

**NEW CANAAN PUBLIC SCHOOLS
Nancy J. Harris
Office of Director of Finance and Operations
39 LOCUST AVENUE
NEW CANAAN, CT 06840
203-594-4025**

**REQUEST FOR PROPOSAL
RFP #2015-03
REHABILITATION OF PLAYGROUND AND LANDSCAPING AT THE SOUTH
ELEMENTARY SCHOOL**

Notice is hereby given that sealed RFPs on the following will be received at the Office of the Director of Finance and Operations until:

April 14, 2015 at 1:00 pm, EST

at which time they will be publicly opened and read aloud:

**RFP #2015-03
REHABILITATION OF PLAYGROUND AND LANDSCAPING AT THE SOUTH
ELEMENTARY SCHOOL**

Specifications, if not attached, may be obtained at the office of:

**Nancy J. Harris
Interim Director of Finance and Operations
New Canaan Public Schools
39 Locust Avenue
New Canaan, CT 06840**

The Board of Education reserves the right to reject any and all proposals, or any part thereof, to waive defects in the same, or to accept any proposal it deems to be in the best interest of the Board of Education and/or the Town of New Canaan.

Questions regarding this bid should be directed to Robert Willoughby, Facilities Manager, at 203-594-4510 or 203-594-4511.

NEW CANAAN PUBLIC SCHOOLS

REQUEST FOR PROPOSALS
Contractor Services Associated with:

**REHABILITATION OF PLAYGROUND AND LANDSCAPING AT THE SOUTH
ELEMENTARY SCHOOL
NEW CANAAN, CT**

GENERAL

New Canaan Public Schools (NCPS) solicits proposals from LICENSED CONTRACTORS to perform REHABILITATION OF PLAYGROUND AND LANDSCAPING AT THE SOUTH ELEMENTARY SCHOOL, 8 Farm Road, New Canaan, CT.

Furnish all materials, equipment, and labor related to project drawings and specifications. Work is to be scheduled as soon as school is dismissed for the summer and as weather conditions allow per the product manufacturer's recommendations.

Project Drawings and Specifications are available online at www.ncps-k12.org

SCOPE OF WORK

The scope of work, without limiting the generality thereof, consists of furnishing all labor, material, equipment necessary to complete the project as indicated on the drawings and as specified. The selected CONTRACTOR(S) will provide shop drawings, catalog cuts and all submissions for approval to Eberlin & Eberlin, PC.

PROPOSAL AND SUBMITTAL PROVISIONS

Proposal price is to be complete turnkey price.

THE PROPOSALS SHALL INCLUDE:

1. Vendors will submit three (3) sets of their sealed proposal on enclosed PROPOSAL SHEET.
2. Vendors will submit three (3) sets of their qualifications to include:
 - a. A firm background or profile
 - b. A statement of experience
 - c. A statement of staff availability with their experiences and backgrounds. (Ensure that the Project Manager assigned to the job has knowledge of this proposal and is qualified by the membrane manufacturers to direct the effort.)
 - d. A list of any and all proposed subcontractors to be utilized on the project.
 - e. A projected time schedule of the work. It is expected that the work will be completed by **AUGUST 15, 2015.**

3. Project security payable to the New Canaan Public Schools in the form of a certified check or payment bond is required for five percent (5%) of the amount bid, issued by an acceptable surety on AIA document A311 or comparable legal bond form, and must accompany each proposal.
4. The successful vendor shall provide using AIA documentation forms for the following; Contract, Performance, and Payment bond within ten days of notification of project award.
5. The successful Contractor shall be required to provide a one (1) year contractor's labor and materials warranty.

SUBMISSION REQUIREMENTS

Respondents shall submit three (3) sets of their proposal. Proposals will be received at New Canaan Public Schools, 39 Locust Avenue, 3rd Floor, New Canaan, CT 06840, ATTN: Nancy Harris, Interim Director of Finance & Operations, until April 14, 2015 at 1:00 pm, EST, at which time they will be opened and publicly read aloud. No fax or email submissions will be accepted.

Ms. Nancy Harris
Interim Director of Finance & Operations
New Canaan Public Schools
39 Locust Avenue, 3rd Floor
New Canaan, CT 06840

Questions regarding this RFP may be directed to Robert Willoughby, Facilities Manager at 203-594-4510 or robert.willoughby@ncps-k12.org.

A mandatory walk through is scheduled for April 2, 2015 at 10:00 am. Walk through at South Elementary School, 8 Farm Road, New Canaan, CT 06840.

All proposals must be signed by an Officer of the Company.

The following items are attached:
Terms and Conditions
Proposal Sheet

SPECIFICATIONS

RFP # 2015-03

**REHABILITATION OF PLAYGROUND AND LANDSCAPING AT THE SOUTH
ELEMENTARY SCHOOL**

Due on or before **April 14, 2015** at the office of:

**Nancy J. Harris
Interim Director of Finance and Operations
NEW CANAAN PUBLIC SCHOOLS
39 LOCUST AVENUE, Room 300
NEW CANAAN, CT 06840**

Sealed proposals will be received by the Business Department of the New Canaan PUBLIC SCHOOLS of the Town of New Canaan, Connecticut until 1:00 pm on April 14, 2015. Each proposal should be clearly marked (example) "**RFP #2015-03 – REHABILITATION OF PLAYGROUND AND LANDSCAPING AT THE SOUTH ELEMENTARY SCHOOL**". Specifications, instructions and proposal forms may be obtained at the above address. Faxed copies of the proposal will not be accepted.

CONDITIONS FOR SUBMITTING PROPOSALS

1. The Board of Education reserves the right to reject any proposal if it is deemed to be in the best interests of the Town of New Canaan, Connecticut, New Canaan Public Schools and its students.
2. The Board of Education reserves the right to grant an award in total or for any part thereof for the items or services being proposed. In addition, the Board of Education reserves the right to award this project as a package in conjunction with other proposals for similar services/supplies/equipment. The Board reserves the right to award with preference to State of Connecticut contract holders and/or local vendors.
3. The submission of a proposal shall be conclusive evidence that the vendor has satisfied himself as to the requirements of the RFP specifications and any controlling conditions which may exist.
4. Vendors may not withdraw their proposal for a period of 120 days from the date of RFP opening. The Board of Education and the vendor may mutually agree to extend the time limit.
5. In determining the ranking of responsible vendors, the Board of Education may consider, in addition to price, the quality, availability and type of items, the experience of the vendor, the sufficiency of the financial resources of the vendor and the reputation of the vendor for ability, integrity, judgment and performance, as well as the ability of the vendor to provide future service/supplies/equipment.
6. It is anticipated that the goods will be needed for the current school year, but the Board of Education reserves the right to cancel or alter this service because of enrollment changes, budget consideration or unforeseen circumstances which require a change.

7. All proposal prices are to include the complete costs, which includes inside delivery to each school or location with installation and assembly of same, if applicable, and training, if applicable. All deliveries must be made prepaid and must be delivered to the location subsequently designated on the purchase orders at no cost over and above the bid price indicated in your proposal. Deliveries must be made inside building indicated. In no case will collect shipments or sidewalk deliveries be accepted. A packing slip shall be included in each shipment. All packages must be clearly marked as to content.
8. The Board of Education of the Town of New Canaan supports efforts to reduce the use of illegal drugs in the workplace. In instances where responsible prospective bidders submit identical tie bids, preference shall be given to the businesses with drug-free workplace programs. Whenever two or more proposals which are equal with respect to price, quality, and service are received by the Board of Education for the procurement of commodities or contractual services which are proposed, a proposal received from a business which has certified that it has implemented a drug-free workplace program shall be given preference in the award process. The drug-free workplace program certification is attached and is to be submitted with the proposal package by the vendor along with other proposal documents in order to receive preference. This policy shall become effective in accordance with the provisions of the Charter of the Town of New Canaan regarding proposal procedures.
9. **ALTERNATIVES:** When proposing an alternate item, indicate the Brand and Model identification on the specification sheets. To have alternates considered, complete specifications must be provided and catalogues describing the product must accompany the bid. The New Canaan Public Schools reserves the right to request equipment samples on specific items.
10. **SUBSTITUTIONS: No substitutions**

The New Canaan Public Schools reserves the right to request equipment samples on specific items.
11. **FORM AND STYLE OF PROPOSAL:** All blanks on the Proposal Sheet, except where otherwise requested, shall be filled in by typewriter or manually in ink and must be completely legible.
12. **WARRANTIES:** Whenever an item or service is covered by a specified product or service warranty, such warranties must be submitted with the official proposal or quotation specification sheets. All such warranties shall inure to the benefit of the Board.
13. **INSURANCE REQUIREMENTS:** The successful vendor will be required to purchase from and maintain, for the life of the contract, in a company or companies with an A.M/Best rating of A- (VII) or better, such insurance as will protect the Board of Education from claims set forth below which may arise out of or result from the vendor's obligation under the Contract, whether such obligation is the vendor's or a subcontractor or any person or entity directly or indirectly employed by the successful vendor or anyone for whose acts said vendor may be liable.
14. **Workers Compensation:**
Vendor shall provide workers compensation insurance required by law with employer's liability limits for at least the amounts of liability for bodily injury by accident of \$ 500,000 each accident and bodily injury by disease of \$500,000.

15. **Commercial General Liability Insurance:**

Vendor shall provide commercial general liability insurance policy with an edition of 1986 or later including products and completed operations. Limits should be at least: Bodily injury and property with an occurrence limit of \$1,000,000; Personal & advertising injury limit of \$1,000,000 per occurrence; General aggregate limit of \$2,000,000 (other than products and completed operations); Products and completed operations aggregate limit of \$2,000,000. Coverage will continue three years after the completion of the work.

- The policy shall name the New Canaan Public Schools as an additional insured and include ISO Form CG2010 (07/04) and CG 2037 (07/04).
- Such coverage will be provided on an occurrence basis, and will be primary, and shall not contribute in any way to any insurance or self-insured retention carried by the Board of Education.
- The policy shall contain a waiver of liability in favor of the Board of Education.
- Such coverage shall contain a broad form contractual liability endorsement or wording within the policy form to comply with the hold harmless and indemnity provision of the contract.
- A per project aggregate limit of liability endorsement shall apply for any construction contract.
- Deductible and self-insured retentions shall be declared and are subject to approval by the Board of Education.

16. **Commercial Automobile Insurance:**

Vendor shall provide commercial automobile insurance for any owned autos (symbol 1 or equivalent) in the amount of \$1,000,000 each accident covering bodily injury and property damage on a combined single limit basis. Such coverage shall also include hired and non-owned automobile coverage. Policy shall name the Board of Education as an additional insured.

17. **Umbrella Liability Insurance:**

Vendor shall provide an umbrella or excess liability policy in excess (without restriction or limitation) of those limits and coverages described in items (A) through (C). Such policy shall contain limits of liability in the amount of \$5,000,000 each occurrence and \$5,000,000 in the aggregate.

As to the insurance required, the insurer(s) and/or their authorized agents shall provide the Board of Education certificates of insurance prior to execution of the agreement by the Board of Education describing said coverage.

18. **QUESTIONS:** For questions regarding the proposal process, contact Nancy Harris, Interim Director of Finance and Operations, at (203) 594-4025.

For questions regarding the project, contact Robert Willoughby, Facilities Manager at 203-594-4510 or 203-594-4511.

NOTE: By submitting a proposal for this contract the vendor agrees that any or all past clients may be contacted by the New Canaan School District. The vendors quoting on this contract also agree to release and discharge by quoting on this contract for the vendor him/herself, his/her heirs executors administrators and assigns, release acquit and forever discharge the New Canaan School System, its Board of Education and all employees and any or all other persons, firms and corporations of and from any and all actions, causes of actions, claims or demands for damages, costs, loss of services, expenses, compensation, consequential damage or any other thing whatsoever, on account of, or in any way growing out of any former client contacted by the New Canaan School System to obtain an opinion regarding any work performed by your company. The above release shall also include and apply to any former client contacted.

DRUG-FREE WORKPLACE CERTIFICATE

I hereby certify that this company:

1. Has a published statement notifying employees that the unlawful manufacture, distribution, dispensing, possession, or use of a controlled substance is prohibited in the workplace and that this statement specifies the actions which will be taken against employees for violations of such prohibition.
2. Has a written policy informing employees about the dangers of drug abuse in the workplace, the firm's policy of maintaining a drug free workplace, any available counseling, rehabilitation, and employee assistance programs, and the penalties which may be imposed upon employees for drug abuse violations.
3. Each employee engaged in providing the commodities or contractual services which are being bid was given a copy of the statements specified in paragraphs 1 and 2, above.
4. In the statement specified in paragraph 1, the employees have been notified that, as a condition of working on the commodities or contractual services which are under bid, the employee will abide by the terms of the statement and will notify the employer of any conviction of, or plea of "guilty" or of "nolo contendere" to any violation of any controlled substance law of the United States or of any state, for a violation occurring in the workplace no later than five (5) days after such conviction or plea.
5. This firm will impose a sanction on or require the satisfactory participation in a drug abuse assistance program or a rehabilitation program, if such are available in the employee's community, by any employee who is so convicted.
6. This firm will make a good faith effort to continue to maintain a drug free workplace.

As the person authorized to sign this statement, I certify that this firm fully complies with the above requirements.

Signature: _____ **Date:** _____

Print Name: _____

Company: _____

**Appendix A
INSURANCE PROCEDURE
NEW CANAAN PUBLIC SCHOOLS
NEW CANAAN, CT**

PLEASE NOTE:

RETURN THIS COMPLETED FORM WITH YOUR PROPOSAL. FAILURE TO DO SO MAY RESULT IN YOUR PROPOSAL BEING REJECTED.

Please take the insurance requirements of the PROPOSAL to your agent/broker immediately upon receipt of the RFP documents to determine your existing coverage and any costs for new or additional coverage required for the work noted in RFP. Any PROPOSALS's that contain exceptions to the insurance requirements may be considered non-responsive and may be rejected.

STATEMENT OF VENDOR:

I have read the insurance requirements for this work and have taken the documentation to my insurance agent/broker. BID/RFP cost reflects any additional costs relating to insurance requirements for this work.

If I am awarded this CONTRACT, I or my insurance agent shall submit all of the required insurance documentation to NEW CANAAN PUBLIC SCHOOLS Business Office within ten (10) days after the date of the award.

Signature

Date

Print Vendor Name

TERMS AND CONDITIONS

THIS IS A REQUEST FOR PROPOSALS AND THE NEW CANAAN PUBLIC SCHOOLS RESERVES THE RIGHT TO NEGOTIATE AND CONTRACT WITH ANYONE OR NO ONE IN THE BEST INTERESTS OF THE TOWN.

NCPS RESERVES THE RIGHT TO AWARD ONE, TWO, OR ALL OF THE PROJECTS TO THE SAME CONTRACTOR.

Unless otherwise modified, the following terms and conditions will apply to services rendered. The respondent may use a standard form of agreement incorporating the following provisions.

Services to be Provided

The winning vendor shall provide services as set forth in the RFP and in accordance with the terms identified herein. The services provided will be performed on behalf of and solely for the New Canaan Public Schools and any information, tests, reports, correspondence, and conclusions shall not be released to other parties unless authorized by NCPS or in accordance with any applicable state or federal law.

Billing and Payment

New Canaan Public Schools will pay the winning vendor for services performed in accordance with the signed Agreement. Invoices will be submitted periodically or upon completion of services rendered. The Town reserves the right to request substantiating information on any bill submitted. The Town will, within 30 days after receipt of an invoice requesting payment, and with the approval of the Town, indicate the approval of payment and process the invoice or indicate to the winning vendor in writing, the reason for refusing to approve said invoice. In the latter case, the winning vendor will make the necessary corrections and resubmit the invoice.

Court Litigation and Waiver of Jury Trial

Notwithstanding the existence of any provision for arbitration of disputes in the contract or any legislation providing for arbitration, any dispute arising under this contract shall not be submitted to arbitration and the parties shall be left to the remedies at law. It is further expressly agreed that both parties waive and relinquish their right to a trial by jury of any dispute arising out of this contract. The intent of the parties is not to have a jury decide any aspect of any dispute which may arise under this contract.

Mediation

All claims, disputes or other matters in question between the parties to this Agreement arising out of or relating to this Agreement or breach thereof shall be submitted to non-binding mediation. On the written notice of either party to the other of the election to submit any dispute under this Agreement to mediation, each party shall designate its representative and shall meet at the New Canaan Town Hall within ten (10) days after the service of notice. The parties themselves shall then attempt to resolve the dispute within ten (10) days of meeting.

Should the parties themselves be unable to agree on a resolution of this dispute, then the parties shall appoint a third party, who shall be a competent and impartial party and who shall be acceptable to each party, to mediate the dispute. Each party shall pay the fees and expenses of the party mediator and such

costs shall be borne equally by both parties. Upon agreement of the parties, either party may waive the first step in the mediation process and appoint a mutually acceptable mediator.

Any third party mediator designated to serve in accordance with the provisions of the Agreement shall be disinterested and shall be qualified to evaluate the performance of both parties.

This process shall be considered as a condition precedent to moving to court.

Equitable Relief

Nothing herein shall prevent either party from obtaining a court order enforcing the mediation process or such other temporary or equitable relief until such time that the dispute is settled or finally adjudicated.

PROPOSAL SHEET

NEW CANAAN PUBLIC SCHOOLS

**REHABILITATION OF PLAYGROUND AND LANDSCAPING
AT THE SOUTH ELEMENTARY SCHOOL
NEW CANAAN, CT**

Having carefully examined the Instructions to Vendors, Equipment / Material Specifications, Scope of Work, Standard Bid/RFP and Contract Terms and Conditions, the site(s) where the work is to be performed, all applicable legal requirements and having made such independent investigations as the respondent deemed necessary, the undersigned hereby submits a proposal to perform the playground and landscaping rehabilitation at South Elementary School in New Canaan CT.

In submitting this proposal, the vendor represents that this proposal will remain effective for one hundred twenty (120) days following the proposal due date.

A. Project Cost and Construction Administration:

For providing all work, labor, materials, equipment, transportation, insurance and all else whatsoever required to completely finish all work in connection with the playground/landscape rehabilitation:

<u>South School Playground Rehabilitation</u>	<u>Written Amount</u>
Rehabilitation of Playground and Landscaping at The South Elementary School	_____

If awarded this contract, we will execute an AIA contract with New Canaan Public Schools, Owner of the properties.

*Prices given are the final price to the Owner and include all permits, fees, overhead and profit of the Vendor.

Company Name: _____

Address: _____

Email: _____ Phone: _____

Name: _____ Title: _____

Signature: _____ Date: _____

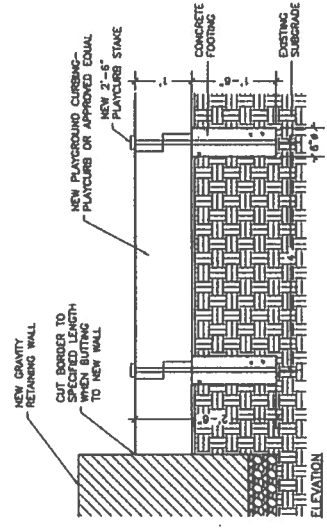

1. LAWN - TURF RESTORATION DETAIL
NOT TO SCALE

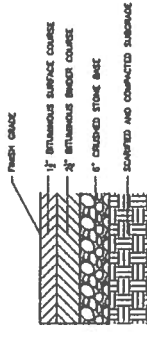

2. ASPHALT PAVEMENT
NOT TO SCALE

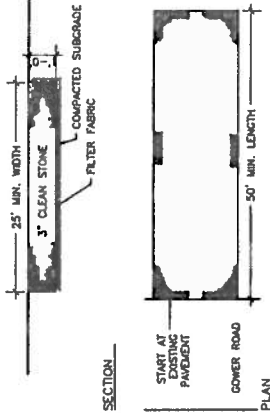

3. ASPHALT ACCESSIBLE RAMP DETAIL
NOT TO SCALE

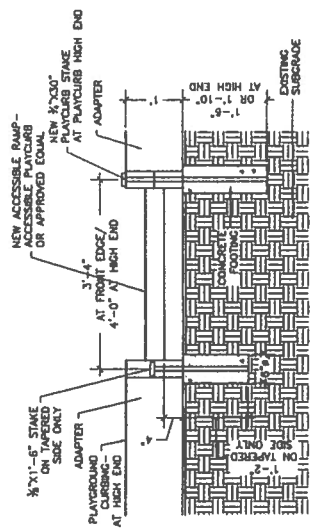

4. PLAYGROUND ACCESSIBLE RAMP DETAIL
NOT TO SCALE

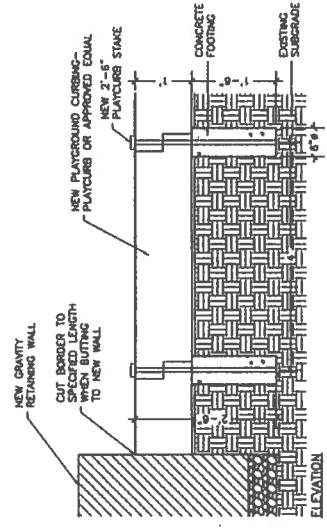

5. PLAYGROUND CURBING DETAIL
NOT TO SCALE

INSTALLATION NOTES: 1. FRESH GRAZE SHALL BE RESEED AS REQUIRED. 2. LAYOUTS ARE REQUIRED, BUT NOT LESS THAN 50 FEET (EXCEPT ON A SINGLE RESIDENCE LOT WHERE A 20 FOOT MINIMUM LENGTH WOULD APPLY). 3. WIDTHS SHALL BE 20 FEET MINIMUM, BUT NOT LESS THAN THE FULL WIDTH AT POINTS WHERE FRESH GRAZE IS PLACED OVER THE EXISTING AREA PRIOR TO PLACING OF STONE. 4. FRESH GRAZE SHALL BE PLACED OVER THE EXISTING AREA PRIOR TO PLACING OF STONE. 5. FRESH GRAZE SHALL BE PLACED OVER THE EXISTING AREA PRIOR TO PLACING OF STONE. 6. FRESH GRAZE SHALL BE PLACED OVER THE EXISTING AREA PRIOR TO PLACING OF STONE. 7. MAINTENANCE-ONE DISTANCE SHALL BE MAINTAINED IN A CONDITION WHICH WILL PROTECT THE FRESH GRAZE FROM PUBLIC RIGHT OF WAY. 8. MAINTENANCE-ONE DISTANCE SHALL BE MAINTAINED IN A CONDITION WHICH WILL PROTECT THE FRESH GRAZE FROM PUBLIC RIGHT OF WAY. 9. MAINTENANCE-ONE DISTANCE SHALL BE MAINTAINED IN A CONDITION WHICH WILL PROTECT THE FRESH GRAZE FROM PUBLIC RIGHT OF WAY. 10. MAINTENANCE-ONE DISTANCE SHALL BE MAINTAINED IN A CONDITION WHICH WILL PROTECT THE FRESH GRAZE FROM PUBLIC RIGHT OF WAY. 11. MAINTENANCE-ONE DISTANCE SHALL BE MAINTAINED IN A CONDITION WHICH WILL PROTECT THE FRESH GRAZE FROM PUBLIC RIGHT OF WAY. 12. MAINTENANCE-ONE DISTANCE SHALL BE MAINTAINED IN A CONDITION WHICH WILL PROTECT THE FRESH GRAZE FROM PUBLIC RIGHT OF WAY.

PLAYGROUND IMPROVEMENTS NOTES: 1. SAFETY MULCH TO BE OF WOOD CHIPPINGS OR WOOD FIBER, MANUFACTURED BY OSMETEC, 801333144, OR 2. COMPACTED MATERIAL, DEPTH TO BE 4\"/>

6. TEMPORARY TRACKING PAD DETAIL
NOT TO SCALE

6. SAFETY MULCH AND PLAYGROUND IMPROVEMENT NOTES
NOT TO SCALE

Consulting Architect
EBERLIN AND EBERLIN, P.C.
31 SODDOM ROAD, BREWSTER, NEW YORK 10509
CONSULTING ENGINEERS, PLANNERS, LANDSCAPE ARCHITECTS
845 582 0358 PHONE 845 279 3062 FAX

Project Title
**SOUTH ELEMENTARY SCHOOL
PLAYGROUND IMPROVEMENTS**
NEW CANAAN, CT

Drawing No.
L-3
SHEET 4 OF 4

Site Construction Details

Contractor	AS NOTED
Checker	RT
Designer	LCJ
Date	13 MARCH 2015

8 FARM ROAD
NEW CANAAN, CT